



**CLEVELAND
VIBRATOR COMPANY**

INSTALLATION • OPERATION • MAINTENANCE

PNEUMATIC VIBRATORS



**INSTALLATION • OPERATING • MAINTENANCE
MANUAL FOR PNEUMATIC VIBRATORS****CONTENTS**

General	1
Installation	1-4
Component Maintenance	5
Operation	6
Special Notes	
Miniature Piston Vibrators	7
TurboMite Vibrators	8
Single Impact Vibrators	9-10
Spring Activated Vibrators	11
Ball Vibrators	11
Sizing Guide	12

GENERAL

Thank you for purchasing pneumatic vibrators from the Cleveland Vibrator Company. Pneumatic vibrators ensure better material flow through bins and hoppers.

INSTALLATION

PNEUMATIC VIBRATORS

OVERVIEW

Vibratory Equipment

When pneumatic style units are being used as vibratory drives on equipment such as feeders, conveyors, screeners, tables, etc. it is assumed that the design of the equipment has taken into consideration the stresses being created.

Hoppers, Bins & Chutes

For hopper, bin and chute applications, the air piston style units have been designed to bolt directly onto a length of either structural channel or a stiff plate, the channel or plate is, in turn, stitch welded to the hopper wall or underside of the chute.

Usually, a conical hopper or bin will provide sufficient rigidity, so additional reinforcement will not be necessary. In such cases, CVC recommends the use of our mounting channel (or suitable replacement) to be used as the mounting bracket.

Vibrator Placement

Pneumatic vibrators should be located at a point on the bin or hopper where bridging of the material is known to occur. If bridging occurs randomly or cannot be determined, mount the unit as shown in Figure 1.

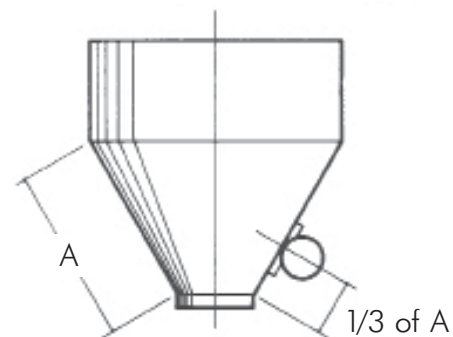
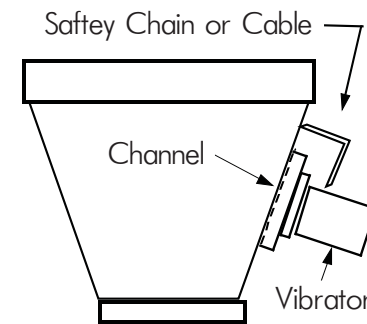
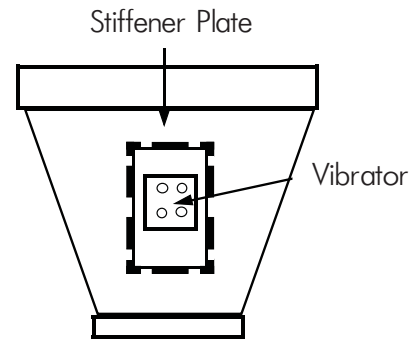

▲ Figure 1

Mounting Suggestions

Pneumatic vibrators are easily mounted to a wide variety of equipment. Illustrated below are just a few installations of vibrators mounted to bins, chutes, tables, screeners and pipes. When installations are made in accordance with our recommendations, we guarantee satisfaction.



Synchronize the action of your vibrator with the opening and closing of the gate by mounting a CVC JN quick acting valve near the gate handle. Connect the JN handle and gate handle with cable and spring illustration as illustrated. When gate handle is pulled, the vibrator will start automatically to ensure flow of material.



Mount a vibrator to the underside of the vibrating tables. A wide range of vibrators are available for your particular need. Design the table so the top is rigid. To control amplitude, incorporate a CVC air regulator in the system.

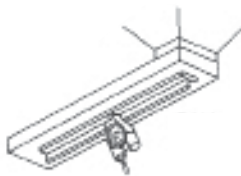

Install a vibrator on your hopper's discharge chute. Weld a piece of 'T' angle to the bottom of the chute and attach vibrator to the angle.



You can easily fabricate a special mounting plate for a chute by fabricating a mounting bracket to bridge the top or open side of the chute. If a standard size structural channel will bridge, then this could be used to simplify this installation.

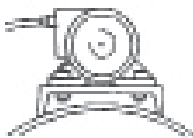

A vibrator mounted on CDMP mounting plate can solve your problem on cylindrical bins and hoppers. The CDMP can easily be welded to a curved surface and will provide strong and rigid installation.



Speed up your screening operation by mounting one or two appropriately sized vibrators to the unit.

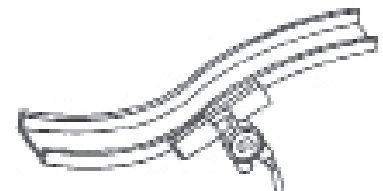

No need to experience clogging or material slowdown on chutes of a curved configuration. Simply weld a piece of 'T' or 'L' iron to the side of the chute at the trouble spot and bolt on an appropriately sized vibrator.

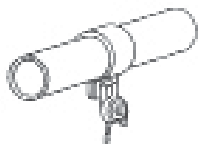

No need to hammer tubular feeders or pipe discharges. Simply strap an appropriate vibrator to the system.

WELDING

WELDING INSTRUCTIONS

Regardless of the type of mounting bracket being used (channel, channel with angle runners, plate, etc.), never continuously weld it to the wall. A stitch weld should be used every one to two inches, skipping an equal distance between the welds.

Regardless of the type of bracket being used, **never continuously weld** it to the hopper wall. A stitch weld should be used every one inch, skipping an equal distance between welds. **Never** weld the ends or corners of the bracket, as cracking of the hopper wall could result. Keep all ends and corners of the bracket free for a distance of one inch. Typical welding pattern is shown in Figure 2.

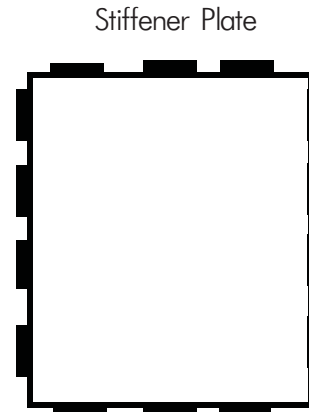

▲ Figure 2

MOUNTING CHANNEL

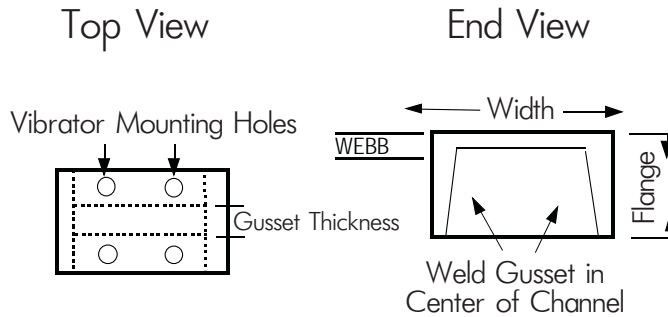

◀ Mounting Channel

MOUNTING CHANNEL

It is recommended that the factory-mounting channel be used with pneumatic vibrators. However, if this vibrator is to be installed on an existing mounting channel, it may be necessary to reinforce the old channel with a scab plate.

Use a piece of 3/8" steel plate cut to size and drilled with bolt holes corresponding to those on the existing mounting channel. The plate is installed between the vibrator and existing mounting channel.

BOLT TORQUE CHART

Diameter & Threads Per Inch	Stress Area in Square Inches	Tensile Strength Minimum KSI	Proof Load in Pounds	Clamp Load in Pounds	Torque Dry in Foot Pounds*	Torque Lubricated in Foot Pounds**
1/4 • 20	.0318	120	2,700	2,020	8	6.3
1/4 • 28	.0364	120	3,100	2,320	10	7.2
5/16 • 18	.0524	120	4,450	3,340	17	13
5/16 • 24	.0580	120	4,900	3,700	19	14
3/8 • 16	.0775	120	6,600	4,950	30	23
3/8 • 24	.0878	120	7,450	5,600	35	25
7/16 • 14	.1063	120	9,050	6,780	50	35
7/16 • 20	.1187	120	10,100	7,570	55	40
1/2 • 13	.1419	120	12,100	9,050	75	55
1/2 • 20	.1599	120	13,600	10,200	85	65
9/16 • 12	.1820	120	15,500	11,600	110	80
9/16 • 18	.2030	120	17,300	12,950	120	90
5/8 • 11	.226	120	19,200	14,400	150	110
5/8 • 18	.256	120	21,800	16,350	170	130
3/4 • 10	.334	120	28,400	21,300	260	200
3/4 • 16	.373	120	31,700	23,780	300	220
7/8 • 9	.462	120	39,300	29,450	430	320
7/8 • 14	.509	120	43,300	32,450	470	350
1 • 8	.606	120	51,500	38,600	640	480
1 • 14	.679	120	57,700	43,300	720	540
1-1/8 • 7	.763	105	56,500	42,300	790	590
1-1/8 • 12	.856	105	63,300	47,500	890	670
1-1/4 • 7	.969	105	71,700	53,800	1,120	840
1-1/4 • 12	1.073	105	79,400	59,600	1,240	930
1-1/2 • 6	1.405	105	104,000	78,000	1,950	1,460
1-1/2 • 12	1.581	105	117,000	87,700	2,200	1,640

NOTE • Torque Values For 1-3/4" Diameter Bolts Are The Same As 1-1/2" Diameter Values

* Use these values if you do not lubricate the bolt.

** Use these values if we supplied equipment with vibrator drive(s) attached.



COMPONENT MAINTENANCE

PNEUMATIC VIBRATORS

COMPONENTS

LUBRO-CONTROL UNIT

Filter • The purpose of the filter is to remove moisture as well as damaging particles before they enter the system. It is essential to maintain a clean filter element by periodic washing.

Lubricator • The lubricator injects into the air stream just enough oil to create a fog that travels with the air and maintains an oil film on the moving part of the precision built vibrator. We recommend the use of automatic lubrication with CVC vibra-lube lubricant. Install the lubricator within 15 feet of the vibrator and in a location where the oil level can be observed.

Regulator • The frequency and force output of the vibrator can be regulated by controlling the line pressure with the regulator. Complete installation and operating instructions accompany the lube-control unit.

Note • If the cap or body is stamped "COATED" the unit is treated with a space-age coating that allows it to run without lubrication. The vibrator can still be lubricated if desired, but it is not necessary.

QUICK ACTING VALVE

A quick acting full ported valve is required to operate this vibrator. The Cleveland Vibrator Company has manual (hand and knee) and electrically operated valves. The pipe thread intake size of the operating valve should be the same as the vibrator pipe thread intake connection size. The valve should be installed within 10 feet of the vibrator and the connection should be completed with oil resistant air hose of ample capacity. Complete hose and male pipe thread fitting assemblies are available from CVC.

WELDS

Periodic visual inspection of welds on the mounting channel and safety chain should be made to ensure no cracks are developing.

HOSES & CONNECTIONS

Periodic visual inspection should be made of all hoses and connections to check for signs of deterioration, cracks, or leaks.

BOLTS

Bolt diameter must correspond to the bolt hole size. Vibration will tend to loosen bolts and nuts during initial few hours of operation.

IMPORTANT • Re-tighten all nuts & bolts uniformly after 2 hours of operation and inspect periodically thereafter. If bolt breakage occurs, replace with high tensile grade #5 bolts which are available from the Cleveland Vibrator Company.

OPERATION

PNEUMATIC VIBRATORS

BEFORE INSTALLATION

BEFORE INSTALLATION

Remove plastic plugs from inlet and outlet ports. Check to ensure the piston moves freely by turning the vibrator upside down and listening for the piston to fall. If no sound is heard mechanically agitate the vibrator several times (alternate ends) to free the piston. Check again for freedom of movement. If no movement is heard, contact supplier for further guidance. Replace the plastic plugs when complete with check. Ensure plastic plugs are removed before installing into system.

OPERATION

OPERATING AIR PRESSURE

Air-powered vibrators will operate on continuous airline pressures within the range of 30-80 p.s.i.g. (pounds per square inch gauge). Optimum vibration efficiency is achieved when clean, 60-80 p.s.i.g. continuous line air pressure is applied. Vibration intensity and frequency may be varied by use of a pressure regulator; vibration intensity is related to applied air pressure.

LUBRICATION*

Inject into the air stream just enough oil to create a fog that travels with the air and maintains an oil film on the moving part of this precision-built vibrator. We recommend the use of automatic lubrication at a rate of 3 drops per minute. Install the lubricator within 15 feet of the vibrator where oil level can be observed. Further installation and operating information accompanies the optional lubricator.

*If the cap or body is stamped 'COATED' the unit is treated with a space-age coating that allows it to run without lubrication. The vibrator can still be lubricated if desired, but it is not necessary.

TROUBLESHOOTING

If vibrator fails to operate, check the following as causes of failure:

- Piston does not move freely – leaky operating valve
- Valve installed backwards (i.e. air supply entering exhaust port)
- Installation of operating valve more than 10 feet from vibrator
- Insufficient volume of air to maintain vibrator's operation
- Dirt or grit in vibrator assembly

If problem still continues to exist after checking above causes contact the supplier.

MINATURE PISTON VIBRATORS

VM

OPERATION

OPERATION AIR PRESSURE

Miniature vibrators will operate on airline pressures within the range of 40PSI/2.7 bar – 80PSI/5.4 bar. Optimum vibrator efficiency is achieved when clean, dry, 60PSI/4.1 bar – 80PSI/5.4 bar air pressure is applied. Vibrator intensity and frequency may be varied by use of a pressure regulator; vibrator intensity is related to applied air pressure.

DURATION OF VIBRATION PERIOD

Most miniature vibrator applications involve automated parts track vibrators, free flow of material from small, thin-skinned (minimum 28 gauge) bins and hoppers up to 2 cubic feet in (57L) capacity. Miniature vibrators are designed for short bursts of vibration. It is recommended to operate the vibrator for only 5-30 seconds in each 1-5 minutes of operation.

LUBRICATION *Optional*

All miniature piston type vibrators have our WS2 Super Grey Coating on the piston. It will not be washed out if lubrication is used. If lubrication is used it would further reduce friction. Inject into the airstream just enough oil to create a fog that travels with the air and maintains an oil film on the moving part of this precision built vibrator. Note: Rule of thumb is to adjust the automatic lubricator to roughly 3 drops per minute.

AIR SUPPLY

Miniature vibrator will operate in any position with adequate clean, dry minimum 60 PSI/4.1 bar air controlled with a quick acting valve located 10 feet or less from vibrator. A quick burst of air is necessary to start the vibrator. However, once the piston is in motion the vibrator will operate off line pressure.

Special Note • For operations below 60 PSI/4.1 bar we recommend mounting the vibrator at 30 degrees. This will allow the vibrator to start and operate trouble free.

TROUBLESHOOTING

If vibrator fails to operate, check the following as causes of failure:

- Piston does not move freely – leaky operating valve
- Valve installed backwards (i.e. air supply entering exhaust port)
- Installation of operating valve more than 10 feet from vibrator
- Insufficient volume of air to maintain vibrator's operation
- Dirt or grit in vibrator assembly

If problem still continues to exist after checking above causes contact the supplier.

TURBOMITE VIBRATORS

CVT • CVT-P • CVT-S

OPERATION

OPERATION AIR PRESSURE

Turbine vibrators will operate on airline pressures within the range of 20PSI/1.4 bar – 80PSI/5.4 bar. Optimum vibrator efficiency is achieved when clean, dry, 60PSI/4.1 bar – 80PSI/5.4 bar air pressure is applied. Vibrator intensity and frequency may be varied by use of a pressure regulator; vibrator intensity is related to applied air pressure.

LUBRICATION

All Cleveland Vibrator turbine vibrators utilize a shielded and sealed ball bearing that is permanently lubricated. The use of additional lubrication applied via the inlet air supply is NOT Recommended or required.

AIR SUPPLY

Turbine vibrators will operate in any position with adequate clean, dry minimum 20 PSI/1.4 bar air controlled with a quick acting valve located 10 feet or less from vibrator. A quick burst of air is necessary to start the vibrator. The smaller turbine units will start and operate with inlet pressures as low as 5 PSI/0.34 bar.

DURATION OF VIBRATION PERIOD

All Cleveland Vibrator turbine vibrators are designed for continuous operation. Pulsing the vibrator with an on/off cycle is also acceptable. For maximum product life, the off cycle is recommended to be at least 10 seconds to allow impeller to come to a full stop.

Shorter off cycles may be achievable if operating at pressure lower than 80 PSI. Please consult Customer Service should a shorter off cycle be needed.

TROUBLESHOOTING

If vibrator fails to operate, check the following as causes of failure:

- Leaky operating valve
- Valve installed backwards (i.e. air supply entering exhaust port)*
- Installation of operating valve more than 10 feet from vibrator
- Insufficient volume of air to maintain vibrator's operation

If problem still continues to exist after checking above causes contact the supplier.

* Exhaust port is the larger diameter hole

SINGLE IMPACT VIBRATORS

SI

OPERATION

- 1 • Energize both electrical and pneumatic systems. Regulate air supply down to 40 PSI.
- 2 • Turn timer switch to ON.
- 3 • Gradually increase the line pressure, which will increase the force developed by the impactor. Arrive at the minimum line pressure that is required to successfully accomplish the impactors' task. **Do not operate the impactor at a higher line pressure than is necessary to do the required job.**
- 4 • By adjusting the timer, arrive at the longest interval possible between impacts that satisfy the job requirement. Increasing the time between impacts prolongs the life of the impactor and conserves air.
- 5 • Double check all electrical and pneumatic connections to be certain all systems are functioning properly.

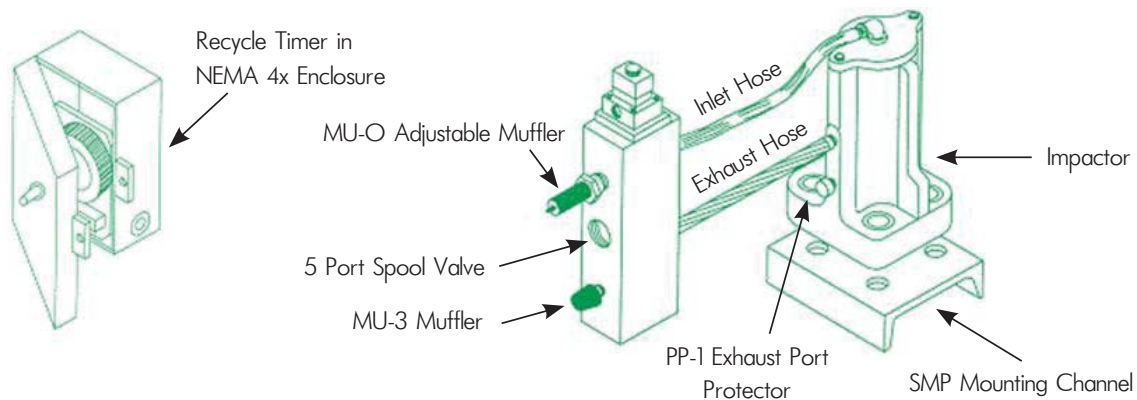

NOTE • Install gasket between mounting channel and impactor.

IMPORTANT • The number two port for 1/2" spool valves and the B port for 3/4" and larger spool valves have been specially modified to restrict the exhausting air passing through it and thereby create a back pressure on the return stroke of the piston. The restricted port and the resulting back pressure are necessary to slow down the piston and prevent it from striking the top cap too hard. If the impactor is allowed to operate without a restriction, the piston will hit against the cap with the same energy as on the impact stroke, which could result in equipment damage or personal injury.

The port restriction has been installed at the factory and will not come out under normal use and operation. At no time should an operator attempt to remove the restriction for any reason.

SAFETY CHAIN

Eyelets have been provided in the body casting of the SI for safety chain hook up. A safety chain of suitable strength for the weight of the impactor should be provided between the eyelet of the impactor and a location of the bin or hopper wall above the impactor. **This is an important safety feature and should not be overlooked.**

MUFFLER & PORT PROTECTORS

Provided with the impactor and spool are (1) type MU-3 muffler, (1) MU-0 adjustable muffler, and (1) PP-1 port protector. The PP-1 port protector should be securely fastened to the lower side port of the impactor.

On the 5 port spool valve, always install mufflers and hoses in the following configuration:

On the three-port side, insert the MU-0 adjustable muffler in the port closest to the solenoid and the MU-3 muffler in the port farthest from the solenoid. On the two-port side, insert the top inlet hose in the port closest to the solenoid and the side inlet hose in the port farthest from the solenoid.

HOSE CONNECTION • IMPACTOR TO SPOOL VALVE

It is recommended that the 5-port spool be mounted within five feet of the impactor. The distance should NEVER exceed ten feet. Proper functioning of the SI requires that only neoprene hose of the proper diameter and wall strength be used. If factory supplied hose is not being used, consult the Cleveland Vibrator Co. for specifications on the proper hose.

The larger diameter hose is connected between the inlet port located in the cap of the impactor and the number 4 port for 1/2" spool valve installations or the "A" port for 3/4" and larger spool valves. The smaller diameter hose is connected between the upper side port of the impactor (refer to illustration) and the number 2 port for 1/2" spool valve, installations or the "B" port for 3/4" and larger spool valves. The main air supply line should then be connected to the number 1 port on 1/2" spool valve installations or the "P" port for 3/4" and larger spool valves. **Be certain that all hose connections are securely fastened and do not leak.**

TIMER

The standard adjustable timer as supplied by CVC is a solid state timer in a NEMA 4x enclosure. One segment of the time cycle allows the operator to adjust the duration of time the impactor impacts. The second segment of the time cycle controls the length of time between impacts.

On Time • 1 to 100 Seconds (2-4 sec. recommended)

Off Time • 1 to 100 Seconds (3-5 sec. or greater recommended)

NOTE • The connection of the timer to the power source as well as the connection of the time to the solenoid head of the spool valve should only be performed by a qualified electrician who is totally familiar with all local codes.

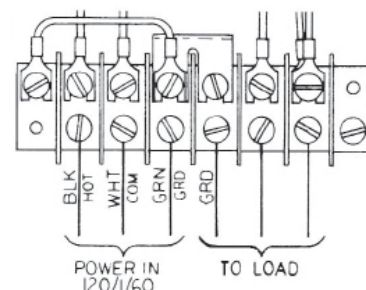

SPRING ACTIVATED VIBRATORS

SA-EP • SAM • ACM

OPERATION

SPRINGS

Not all vibrators require springs. The only function a spring serves is to push the piston into a starting position after the air supply has been turned off and the piston is motionless. If the vibrator is mounted so that the piston operates on about a 30-degree angle off horizontal then gravity will pull the piston into a starting position and a spring is not necessary.

When the piston of an air-powered vibrator touches one or the other of the endheads of the vibrator assembly, it is in a starting position. Due to design changes in springs, it is necessary to specify the type of spring required for replacement. Vibrator springs are either straight cylindrical type, or a conical type.

BALL VIBRATORS

VBM • VBB • VBC • VBD

MATERIAL FLOW

Since the Vibra Ball vibrators produce a rotary motion, most applications will require attaching the unit on the mounting bracket in such a way that the direction of rotation is **with** the flow of material.

OPERATION

Figure 3 and Figure 4 detail the only controls required to operate Vibra Ball vibrators.

Figure 3 ▼

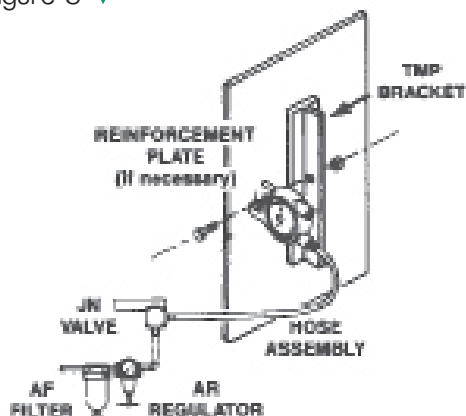
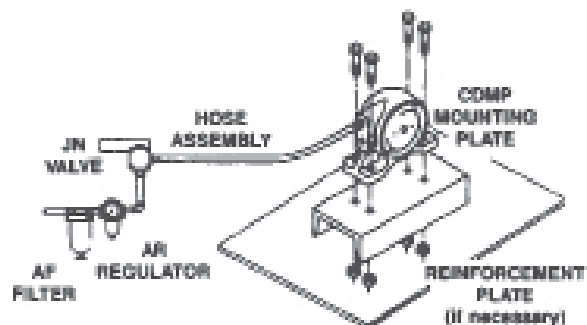

Figure 4 ▼



SIZING GUIDE

Bin Capacity	Approx. Skin Thickness of Bin	Impact Vibrator Size (VMS, VMR)	Non-Impact Vibrator Size (VMSAC, VMRAC, Turbomite)
100 Lbs. / 45 kg	1/8" or less 3.2 mm	VM-25	CVT-P-1
200 Lbs. / 90 kg	1/8" or less 3.2 mm	VM-38	CVT-P-10
300 Lbs. / 136 kg	1/8" or less 3.2 mm	3/4" SA	CVT-P-22 or CVT-P-30
500 Lbs. / 226 kg	1/8" 3.2 mm	1" SA	CVT-P-22, CVT-P-30, or 1125
700 Lbs. / 317 kg	1/8" 3.2 mm	1125	CVT-30, CVT-P-50, or 1150
1 ton / 0.9 MT	3/16" - 1/4" 4.8mm - 6.4 mm	1150	CVT-40, CVT-P-60, or 1200
3 ton / 2.7 MT	3/16" - 1/4" 4.8 mm - 6.4 mm	1200	CVT-80 or 1300
20 ton / 18 MT	5/16" - 3/8" 7.9 mm - 9.5 mm	1300	1350
50 Ton / 45 MT	3/8" 9.5mm - 12.7mm	1350	1400
100 ton / 90 MT	3/8" 9.5 mm - 12.7 mm	1400	1500
100 ton + / 90 MT +	3/4" - 1" 19.1 mm - 25.4 mm	1500	1700

INSTALLATION • The mounting of a vibrator on a length of channel which is stitch welded vertically to the side of a hopper will provide a transmission line above and below the vibrator and will also reinforce the hopper wall as well. The width of the channel should be to suit the base dimensions of the vibrator. The length will also vary with the hopper size, however, a good rule to follow is that the channel be one-third the length of the sloping section of the hopper.

MOISTURE CONTENT • Moisture content of the material to be moved is also important in the sizing of a vibrator. If the moisture content is 6% or more, it is advisable to use the next size vibrator or two vibrators.

FORCE OUTPUT ADJUSTMENTS • All vibrators provide a range of adjustability in their force output. Air vibrators can be adjusted with a simpler air regulator; electric vibrators with adjustable eccentrics; or others with SCR controls. In selecting a vibrator, remember that it can be adjusted due to changes in material make-up, lower hopper contents, or vibrator oversizing.

NON-IMPACT ADJUSTMENTS • There is a reduction in vibration intensity in the nonimpacting type vibrators (air-cushioned piston, rotary electric, turbine and ball) over the impacting piston vibrator. For piston vibrators, to achieve comparable results, the next size non-impacting vibrator should be used.

OPERATION EFFECTIVENESS • A short burst of vibration is normally more effective than continuous vibration. Do not operate vibrators against closed hopper gates or valves.

NOISE LEVEL • Noise level of vibrators varies with the type. A general ranking from loudest to quietest is as follows: impact, ball, air-cushioned, rotary electric and turbine.